

PRODUCT OVERVIEW

eFlow-MAX is a field adjustable High Capacity Constant Airflow Regulator. It is designed to automatically and precisely balance airflow into or out of a space without the need for electricity. Its design saves significant amount of energy, money and provides High Indoor Air Quality. This round damper is designed to provide pressure-independent maximum constant airflow in round duct systems without use of electricity, sensors or controls. As pressure increases, the blade moves to keep airflow stable over a wide pressure range. eFlow-MAX has an external mechanism that can be used to adjust airflow manually, and with ease, using an allen wrench (2mm). eFlow-MAX can be easily installed inside standard ductwork. Mounting may be horizontal or vertical.

eFlow-MAX features laser-welded, heavy galvanized steel body, plastic airflow control and an airtight seal to ensure a no-leak fit. It is also available in stainless steel.

eFlow-MAX is maintenance free and corrosion-proof under normal conditions.

Warranty is guaranteed for Six (6) years, from date of shipment, against all defects in material, given that the material has been installed and used under normal conditions. This warranty is limited to the repair or replacement of material.

eFlow-MAX FACTS

- Diameters offered: 3", 4", 5", 6", 8", 10", 12", 14", 16"
- Operating Pressure Range: 0.2 to 4.0 in w.g. (50-1000Pa)
- Airflow settings: 15-2335 CFM -Suggested Air Speed: 885 FPM
- Temperature Limits: -22° to 212°F (-30° to 100°C)
- Suitable for both supply and exhaust applications
- No external power supply needed
- Field Adjustable CFM setpoint
- Capable of maintaining constant airflow within $\pm 10\%$ for nominal airflow > 60 CFM (100 m3/h) and ± 5 CFM (10 m3/h) for nominal airflow < 60 CFM (100 m3/h) throughout the target operating pressure range of 0.2 to 4.0 in. w.g. (50 to 1000 Pa).
- Sound power levels shall not exceed those for each size and CFM rating as scheduled.
- Laser-welded, heavy galvanized steel body, plastic airflow control and air tightness seal to ensure no-leak fit
- Available in stainless steel
- Energy efficient
- Ideal solution for meeting rooms, classrooms, concert halls, etc.
- Maintenance free and corrosion-proof under normal conditions
- Warranty guaranteed for Six (6) years



Aldes-MR MAX/eFlow-MAX FACTS

- This High Capacity Constant Airflow Regulator is designed and produced by the EU manufacturer and distributed in the USA market under Aldes and eFlow Brands.
- Aldes-MR MAX=eFlow-MAX

eFlow-MAX

Operating Pressure Range 0.2 to 4.0 in w.g. (50-1000 Pa)

DIMENSIONS

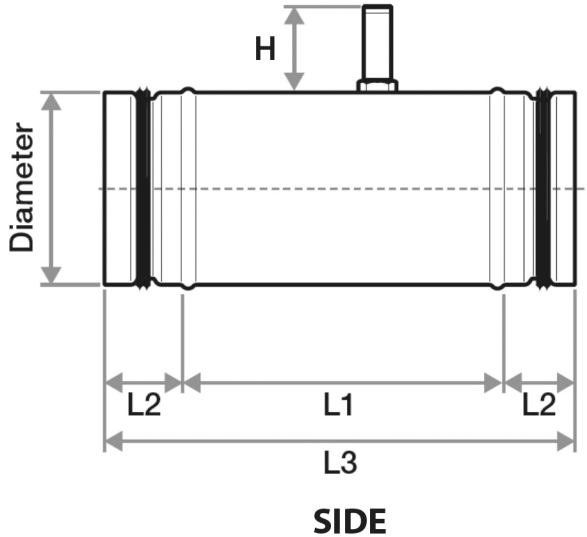

AIRFLOW RANGE

Product Name	Ø DIAMETER	AIRFLOW RANGE
<input type="checkbox"/> eFlow-MAX 3"	3" (80 mm)	24-75 CFM (40-125 m ³ /h)
<input type="checkbox"/> eFlow-MAX 4"	4" (100 mm)	40-130 CFM (70-220 m ³ /h)
<input type="checkbox"/> eFlow-MAX 5"	5" (125 mm)	60-165 CFM (100-280 m ³ /h)
<input type="checkbox"/> eFlow-MAX 6"	6" (150 mm)	100-265 CFM (170-450 m ³ /h)
<input type="checkbox"/> eFlow-MAX 8"	8" (200 mm)	150-530 CFM (250-900 m ³ /h)
<input type="checkbox"/> eFlow-MAX 10"	10" (250 mm)	295-940 CFM (500-1600 m ³ /h)
<input type="checkbox"/> eFlow-MAX 12"	12" (300 mm)	470-1650 CFM (800-2800 m ³ /h)
<input type="checkbox"/> eFlow-MAX 14"	14" (355 mm)	530-1885 CFM (900-3200 m ³ /h)
<input type="checkbox"/> eFlow-MAX 16"	16" (400 mm)	590-2355 CFM (1000-4000 m ³ /h)

Product Name	Ø Diameter	L1	L2	L3	H	Weight
eFlow-MAX 3"	3" (80 mm)	5.31" (135 mm)	1.57" (40 mm)	8.46" (215 mm)	2.76" (70 mm)	0.88 lbs (0.4 kg)
eFlow-MAX 4"	4" (100 mm)	6.69" (170 mm)	1.57" (40 mm)	9.84" (250 mm)	2.76" (70 mm)	1.32 lbs (0.6 kg)
eFlow-MAX 5"	5" (125 mm)	6.69" (170 mm)	1.57" (40 mm)	9.84" (250 mm)	2.76" (70 mm)	1.765 lbs (0.8 kg)
eFlow-MAX 6"	6" (150 mm)	6.69" (170 mm)	1.57" (40 mm)	9.84" (250 mm)	2.76" (70 mm)	2.43 lbs (1.1 kg)
eFlow-MAX 8"	8" (200 mm)	9.45" (240 mm)	1.57" (40 mm)	12.60" (320 mm)	2.76" (70 mm)	3.97 lbs (1.8 kg)
eFlow-MAX 10"	10" (250 mm)	9.45" (240 mm)	1.57" (40 mm)	12.60" (320 mm)	2.76" (70 mm)	5.51 lbs (2.5 kg)
eFlow-MAX 12"	12" (300 mm)	8.66" (220 mm)	3.50" (89 mm)	15.67" (398 mm)	4.33" (110 mm)	11.02 lbs (5.0 kg)
eFlow-MAX 14"	14" (355 mm)	11.81" (300 mm)	2.36" (60 mm)	16.54" (420 mm)	4.33" (110 mm)	12.13 lbs (5.5 kg)
eFlow-MAX 16"	16" (400 mm)	11.81" (300 mm)	2.36" (60 mm)	16.54" (420 mm)	4.33" (110 mm)	16.53 lbs (7.5 kg)

Stainless Steel Option

Job Name:
Location:
Architect:
Engineer:
Contractor:

eFlow-MAX High Capacity Constant Airflow Regulator
(Supply, Exhaust)

DRAWN BY: IL	DATE: 08-24-2018	REV. DATE:	REV. NO.:	APPROVED BY: EL	DWG. NO.:
------------------------	---------------------	------------	-----------	---------------------------	-----------

eFlow-MAX Low Flow

Operating Pressure Range 0.2 to 2.0 in w.g. (50-1000 Pa)

DIMENSIONS

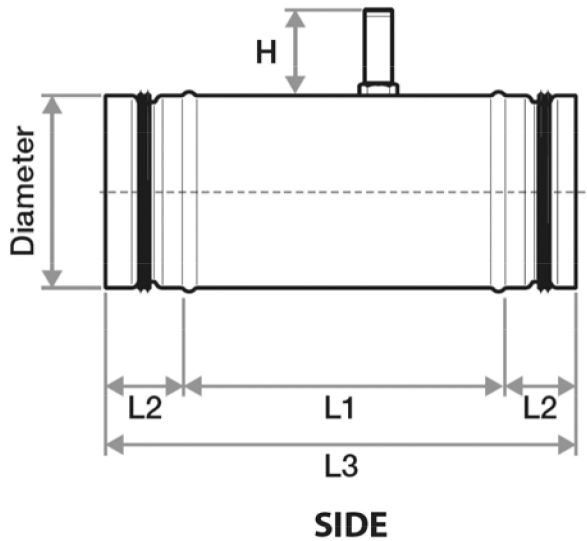

AIRFLOW RANGE

<input type="checkbox"/>	Product Name	Ø DIAMETER	AIRFLOW RANGE
<input type="checkbox"/>	eFlow-MAX LF 3"	3" (80 mm)	15-47 CFM (25-80 m ³ /h)
<input type="checkbox"/>	eFlow-MAX LF 4"	4" (100 mm)	24-74 CFM (40-125 m ³ /h)
<input type="checkbox"/>	eFlow-MAX LF 5"	5" (125 mm)	38-130 CFM (65-220 m ³ /h)
<input type="checkbox"/>	eFlow-MAX LF 8"	8" (200 mm)	95-295 CFM (160-500 m ³ /h)
<input type="checkbox"/>	eFlow-MAX LF 10"	10" (250 mm)	141-470 CFM (240-800 m ³ /h)

Stainless Steel Option

Product Name	Ø Diameter	L1	L2	L3	H	Weight
eFlow-MAX LF 3"	3" (80 mm)	5.31" (135 mm)	1.57" (40 mm)	8.46" (215 mm)	2.76" (70 mm)	0.88 lbs (0.4 kg)
eFlow-MAX LF 4"	4" (100 mm)	6.69" (170 mm)	1.57" (40 mm)	9.84" (250 mm)	2.76" (70 mm)	1.32 lbs (0.6 kg)
eFlow-MAX LF 5"	5" (125 mm)	6.69" (170 mm)	1.57" (40 mm)	9.84" (250 mm)	2.76" (70 mm)	1.765 lbs (0.8 kg)
eFlow-MAX LF 8"	8" (200 mm)	9.45" (240 mm)	1.57" (40 mm)	12.60" (320 mm)	2.76" (70 mm)	3.97 lbs (1.8 kg)
eFlow-MAX LF 10"	10" (250 mm)	9.45" (240 mm)	1.57" (40 mm)	12.60" (320 mm)	2.76" (70 mm)	5.51 lbs (2.5 kg)

Job Name:	<input type="checkbox"/> eFlow-Max LF High Capacity Constant Airflow Regulator (Supply, Exhaust)				
Location:					
Architect:					
Engineer:					
Contractor:					
DRAWN BY: IL	DATE: 08-24-2018	REV. DATE:	REV. NO.:	APPROVED BY: EL	DWG. NO.:

EFLOW-MAX ACOUSTIC DATA

eFlow-MAX High Capacity Constant Airflow Regulator			Static Pressure Difference																													
			0.4 InWC (100 Pa)										1.0 InWC (250 Pa)										2.0 InWC (500 Pa)									
			Octave Power Level L _w (dB/octave)										Octave Power Level L _w (dB/octave)										Octave Power Level L _w (dB/octave)									
Size	CFM	M ³ /hr	63 Hz	125 Hz	250 Hz	500 Hz	1000 Hz	2000 Hz	4000 Hz	8000 Hz	L _w - a = dB(A)	63 Hz	125 Hz	250 Hz	500 Hz	1000 Hz	2000 Hz	4000 Hz	8000 Hz	L _w - a = dB(A)	63 Hz	125 Hz	250 Hz	500 Hz	1000 Hz	2000 Hz	4000 Hz	8000 Hz				
3" (80mm)	24	40	37	37	35	33	33	33	28	27	38	39	42	43	44	44	46	41	41	50	46	49	49	50	51	53	48	48				
	48	82	49	47	44	41	39	39	33	32	45	51	51	50	49	48	49	44	44	54	58	58	56	55	55	56	51	51				
	74	125	52	51	48	45	44	44	38	37	49	61	60	57	54	53	53	47	46	58	68	66	63	61	59	59	53	52				
4" (100 mm)	41	70	40	39	38	36	35	36	30	29	41	43	45	46	46	47	49	44	43	53	49	52	52	53	54	55	50	50				
	80	135	50	48	45	42	41	40	34	33	46	59	57	54	51	50	49	43	42	55	60	60	58	57	57	58	53	52				
	118	200	54	52	49	47	45	45	39	38	51	63	61	58	55	54	54	48	47	59	70	68	65	62	61	60	54	53				
5" (125 mm)	59	100	41	40	38	36	35	36	30	29	41	45	47	47	48	48	49	44	43	54	52	54	54	54	55	56	50	49				
	112	190	51	49	46	42	41	40	34	32	46	55	54	53	51	51	51	46	45	56	61	61	59	58	57	58	52	52				
	165	280	54	53	50	47	45	45	39	37	50	63	61	58	55	54	53	47	46	59	64	64	62	61	61	62	57	56				
6" (150 mm)	89	150	43	42	40	38	37	37	31	30	42	47	49	49	49	50	51	45	44	55	54	56	56	56	56	57	52	51				
	159	270	52	50	46	43	41	41	34	33	47	56	56	54	52	52	52	46	46	57	63	62	60	59	58	59	53	52				
	236	400	56	54	50	47	46	45	39	38	51	64	62	59	56	54	54	48	46	60	65	65	64	62	62	63	57	57				
8" (200 mm)	148	250	45	43	41	39	38	37	31	30	43	51	52	52	51	51	51	45	44	56	57	59	58	58	57	58	52	50				
	339	575	55	53	50	46	44	44	37	36	50	64	62	58	55	53	53	46	45	59	66	66	64	62	62	62	56	56				
	531	900										68	66	63	60	58	58	52	50	64	75	73	70	67	65	65	58	57				
10" (250 mm)	295	500	48	47	45	43	41	41	35	34	47	54	56	55	55	54	55	49	48	60	61	62	62	61	61	62	56	54				
	590	1000	57	55	52	49	47	46	39	38	52	66	64	61	57	55	55	48	47	61	69	68	67	65	64	64	59	58				
	885	1500										70	68	65	62	60	60	53	52	65	77	75	72	68	67	66	60	58				
12" (315 mm)	472	800	48	46	44	41	39	39	32	31	44	55	56	55	54	53	53	46	44	58	62	63	62	61	60	59	53	51				
	826	1400	57	55	52	48	46	45	39	37	51	66	64	60	57	55	54	47	46	60	70	69	67	65	64	64	58	57				
	1298	2200										71	69	65	62	60	59	53	51	65	77	75	72	69	67	66	60	58				
14" (350 mm)	531	900	50	48	46	43	42	41	35	33	47	57	58	57	56	55	55	49	47	60	64	65	64	63	62	62	55	53				
	1180	2000	59	57	53	50	48	47	40	39	53	68	66	62	59	57	56	49	47	62	72	71	69	67	66	66	60	59				
	1888	3200										73	71	67	64	62	61	55	54	68	79	77	74	71	69	68	62	60				
16" (400 mm)	590	1000	50	48	45	42	41	40	33	31	46	58	59	57	56	55	54	47	45	59	65	65	64	62	61	61	54	51				
	1298	2200	58	56	52	49	47	46	39	37	52	67	65	61	57	55	54	48	46	61	72	71	68	66	65	65	59	57				
	2242	3800										73	71	67	64	62	61	55	53	67	79	77	74	70	68	68	61	60				

Airflow noise is dependent on local conditions. Data reported here were determined in a laboratory setting. Your conditions may vary from the example.

EFLOW-MAX LOW FLOW ACOUSTIC DATA

eFlow-MAX-LF High Capacity Constant Airflow Regulator			Static Pressure Difference																										
			0.4 InWC (100 Pa)										1.0 InWC (250 Pa)								2.0 InWC (500 Pa)								
			Octave Power Level										Octave Power Level								Octave Power Level								
			L _w (dB/octave)										L _w (dB/octave)								L _w (dB/octave)								
Size	CFM	M ³ /hr	63 Hz	125 Hz	250 Hz	500 Hz	1000 Hz	2000 Hz	4000 Hz	8000 Hz	L _w -a = dB(A)	63 Hz	125 Hz	250 Hz	500 Hz	1000 Hz	2000 Hz	4000 Hz	8000 Hz	L _w -a = dB(A)	63 Hz	125 Hz	250 Hz	500 Hz	1000 Hz	2000 Hz	4000 Hz	8000 Hz	L _w -a = dB(A)
3" (80mm)	15	25	29	33	32	32	33	28	27	37	37	38	40	40	40	41	42	36	35	46	45	47	47	47	47	48	43	42	53
	30	52	39	39	37	36	35	36	31	30	41	40	43	44	45	46	49	44	44	53	46	49	50	52	53	55	51	51	59
	47	80	48	46	43	41	39	39	33	31	44	51	51	50	48	48	49	44	44	54	57	57	56	55	55	56	51	50	60
4" (100 mm)	24	40	32	34	34	33	33	34	29	27	39	41	42	42	42	43	38	36	48	47	49	49	49	49	50	44	43	54	
	48	82	46	43	40	37	35	35	28	27	41	50	49	48	46	45	46	40	40	51	50	52	53	54	55	57	52	52	61
	74	125	50	48	45	42	40	40	33	32	45	53	53	51	50	50	50	45	45	55	59	59	58	57	56	57	52	51	62
5" (125 mm)	38	65	35	36	36	35	35	36	30	29	41	43	45	45	44	44	45	39	37	49	50	52	51	51	51	51	45	44	56
	84	142	48	46	42	39	37	37	30	29	43	52	52	50	49	48	48	43	42	53	53	55	56	57	57	59	54	54	63
	130	220	52	50	47	44	42	42	36	34	48	61	59	56	53	51	51	44	43	56	62	62	60	59	59	59	54	53	64
8" (200 mm)	160	160	40	41	40	38	38	37	31	29	43	48	49	48	47	46	46	40	38	51	55	56	55	54	53	53	46	44	58
	194	330	50	47	44	40	38	37	30	29	43	56	55	52	50	49	49	43	42	55	58	60	60	60	60	61	55	54	65
	295	500	54	51	48	45	43	42	36	34	48	59	58	56	54	54	54	48	47	59	65	65	63	61	60	61	55	54	66
10" (250 mm)	141	240	42	42	41	39	38	38	31	28	43	51	51	50	48	47	47	40	37	52	57	58	56	55	54	53	46	44	59
	306	520	51	48	45	41	39	38	31	29	44	57	56	54	52	50	50	44	43	56	61	62	62	62	61	62	56	55	67
	470	800	55	53	49	46	44	43	37	35	49	61	60	58	56	55	55	49	48	60	67	67	65	63	62	62	56	55	67

Airflow noise is dependent on local conditions. Data reported here were determined in a laboratory setting. Your conditions may vary from the example.